



WASTEWATER TREATMENT EQUIPMENT





WASTEWATER TREATMENT EQUIPMENT

- Screening Solution to Replace Grinders, Communitors or Manual Screens
 - Aqualitec Corp. Case Studies:
 1. [Mendocino Water District](#)
 2. [Clearlake Oaks County Water District](#)
 3. [Upcoming Project \(Washington State\)](#)
 4. [Upcoming Project \(California\)](#)

1- Mendocino Water District (Northern California)

- Previous Installation



Communitor in a Deep and Narrow Well

1- Mendocino Water District (Northern California)

- Aqualitec' Solution

Screenotec

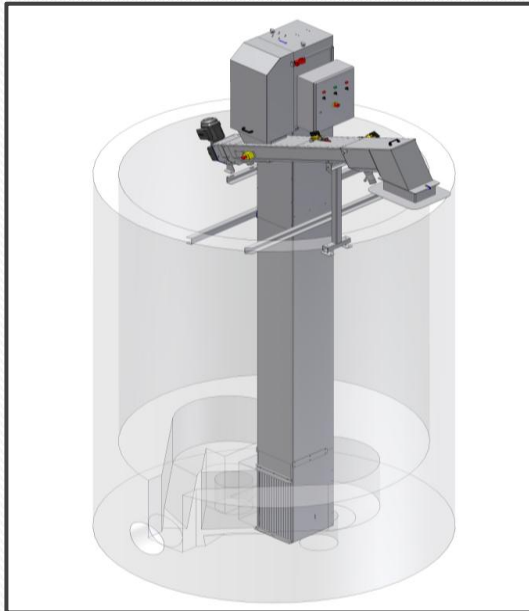

Installation of the Mechanical Vertical Bar Screen to replace the Communitor with no Structural Changes

2- Clearlake Oaks County Water District (Northern California)

- Previous Installation



Grinder in a Narrow Channel

2- Clearlake Oaks County Water District (Northern California)

- Aqualitec's Solution

Raketec



Installation of the Multiple Rake Screen to replace the Grinder with no Structural Changes

3- Upcoming Project (Washington State)

- Current Installation



Grinder in a Narrow Channel

3- Upcoming Project (Washington State)

- Aqualitec' Solution

Screenotec

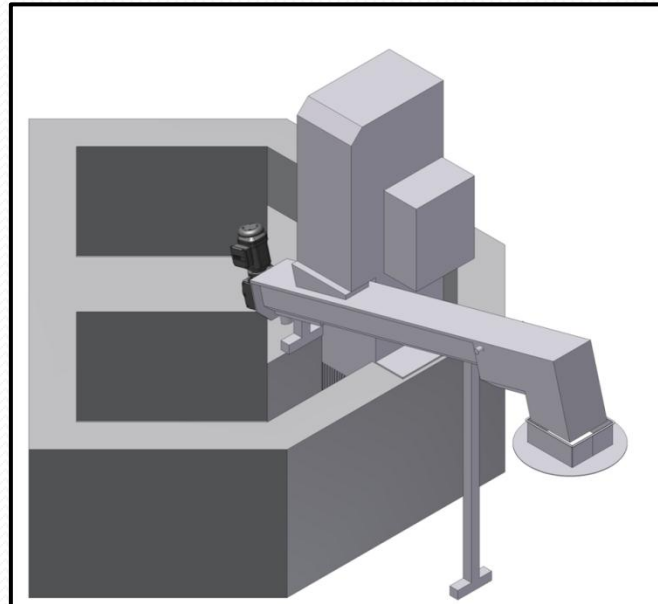
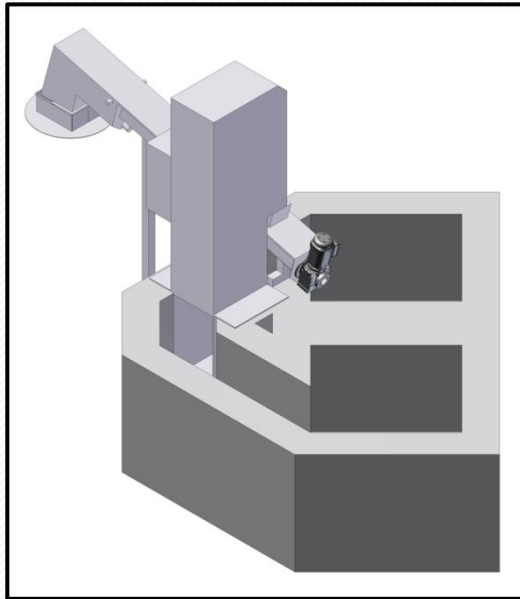

Installation of the Mechanical Vertical Bar Screen to replace the Grinder with no Structural Changes

4- Upcoming Project (California)

- Current Installation



Grinder in a Narrow Channel

4- Upcoming Project (California)

- Aqualitec' Solution

Screenotec

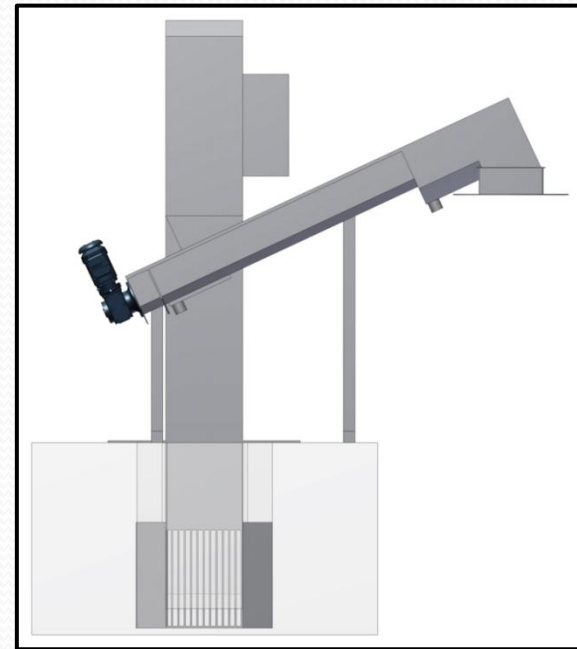
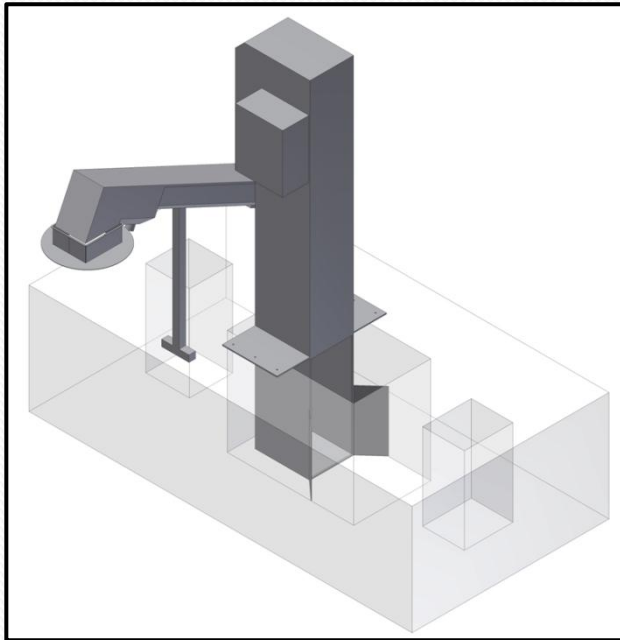

Installation of the Mechanical Vertical Bar Screen to replace the Grinder with no Structural Changes